

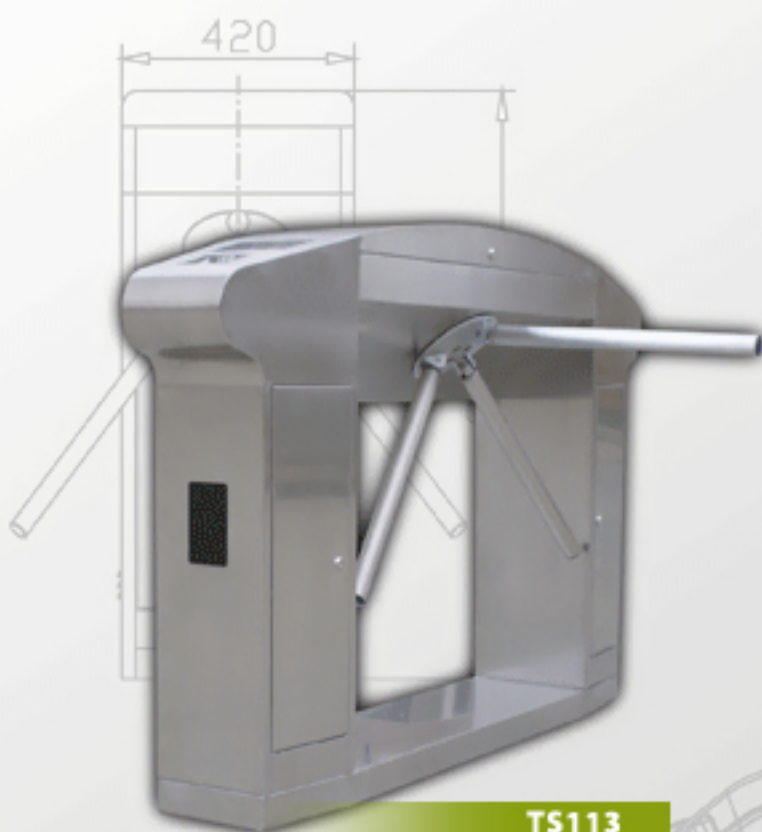

Tripod Turnstile

TS111/112/113



Functions & Features



- 1 . Stainless steel housing.
- 2 . Bi-direction pass.
- 3 . Arms auto drop when power off.
- 4 . Arms auto rise up when power on and auto stop on obstacle.
- 5 . Traffic light indicator.
- 6 . RFID interface.
- 7 . Photoelectric inspection.
- 8 . RS232 socket, LAN socket.
- 9 . If the passenger does not pass in valid time, the passage will be locked up again .The valid passing time can be set up by operator.
- 10.Passenger counter (optional) .

Technical Data

Voltage	220V±10%, 110V±10%
Frequency	50/60Hz
Control Circuit	DC12V
Consumption	30W
Passing Speed	≤ 35 Persons /min
Working Temperature	-20℃~55℃
Protection Grade	IP40
Communication Socket	RS232 standard socket/LAN socket

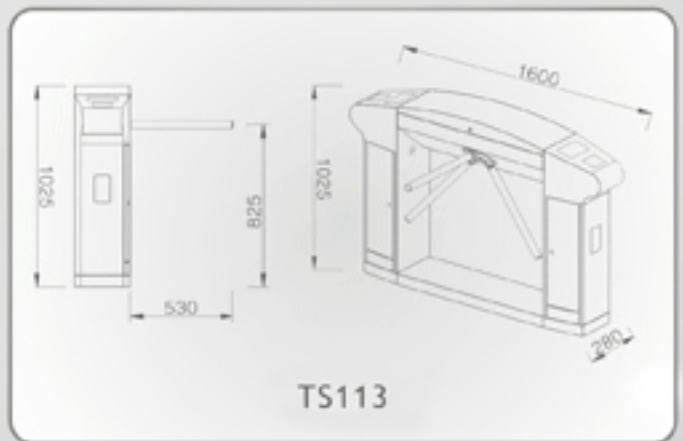
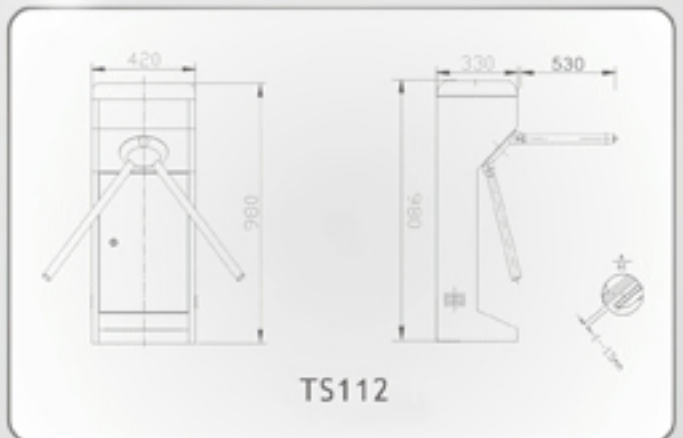
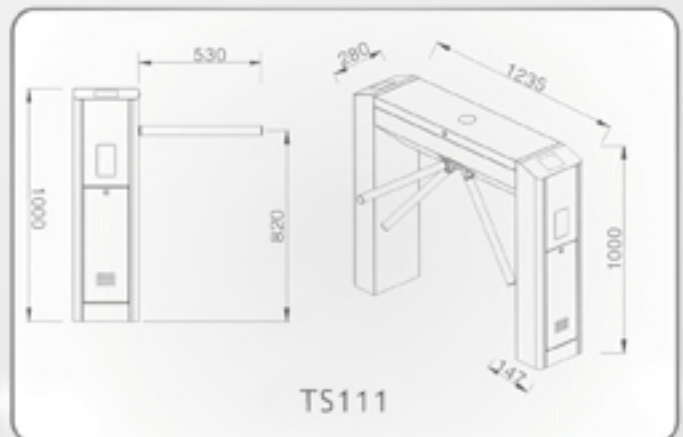

* All Specifications / colors are subject to change without notice. (V.00)